

# Brazed and Gas-to-liquid plate heat exchangers

AC, AXP, CB, CD, DOC, GL, GLX

---



Lit. Code

200001565-3-EN-GB

Instruction Manual

**Published by**  
Alfa Laval Lund AB  
Box 74  
Visit: Rudeboksvägen 1  
226 55 Lund, Sweden  
+46 46 36 65 00  
+46 46 30 50 90  
info@alfalaval.com

**The original instructions are in English**

© Alfa Laval 2023-01

This document and its contents are subject to copyrights and other intellectual property rights owned by Alfa Laval AB (publ) or any of its affiliates (jointly "Alfa Laval"). No part of this document may be copied, re-produced or transmitted in any form or by any means, or for any purpose, without Alfa Laval's prior express written permission. Information and services provided in this document are made as a benefit and service to the user, and no representations or warranties are made about the accuracy or suitability of this information and these services for any purpose. All rights are reserved.



### English

Download local language versions of this instruction manual from [www.alfalaval.com/bhe-manuals](http://www.alfalaval.com/bhe-manuals) or use the QR code

### български

Изтеглете версиите на това ръководство за употреба на местния език от [www.alfalaval.com/bhe-manuals](http://www.alfalaval.com/bhe-manuals) или използвайте QR кода.

### Český

Stáhněte si místní jazykovou verzi tohoto návodu k obsluze z [www.alfalaval.com/bhe-manuals](http://www.alfalaval.com/bhe-manuals) nebo použijte QR kód.

### Dansk

Hent lokale sprogversioner af denne brugervejledning på [www.alfalaval.com/bhe-manuals](http://www.alfalaval.com/bhe-manuals) eller brug QR-koden.

### Deutsch

Sie können die landessprachlichen Versionen dieses Handbuch von der Website [www.alfalaval.com/bhe-manuals](http://www.alfalaval.com/bhe-manuals) oder über den QR-Code herunterladen.

### ελληνικά

Πραγματοποιήστε λήψη εκδόσεων του παρόντος εγχειριδίου οδηγιών σε τοπική γλώσσα από το [www.alfalaval.com/bhe-manuals](http://www.alfalaval.com/bhe-manuals) ή χρησιμοποιήστε τον κωδικό QR.

### Español

Descárguese la versión de este Manual de instrucciones en su idioma local desde [www.alfalaval.com/bhe-manuals](http://www.alfalaval.com/bhe-manuals) o utilice el código QR.

### Eesti

Selle kasutusjuhendi kohaliku keele versiooni saate alla laadida lingilt [www.alfalaval.com/bhe-manuals](http://www.alfalaval.com/bhe-manuals) või kasutada QR-koodi.

### Suomalainen

Laitaa tämän käyttöohjeen suomenkielinen versio osoitteesta [www.alfalaval.com/bhe-manuals](http://www.alfalaval.com/bhe-manuals) tai QR-koodilla.

### Français

Téléchargez des versions de ce manuel d'instructions en différentes langues sur [www.alfalaval.com/bhe-manuals](http://www.alfalaval.com/bhe-manuals) ou utilisez le code QR.

### Hrvatski

Preuzmite lokalne verzije jezika ovog korisničkog priručnika na poveznici [www.alfalaval.com/bhe-manuals](http://www.alfalaval.com/bhe-manuals) ili upotrijebite QR kod.

### Magyar

Az Ön nyelvére lefordított használati útmutatót letöltheti a [www.alfalaval.com/bhe-manuals](http://www.alfalaval.com/bhe-manuals) weboldáról, vagy használja a QR-kódot.

### Italiano

Scarica la versione in lingua locale del manuale di istruzioni da [www.alfalaval.com/bhe-manuals](http://www.alfalaval.com/bhe-manuals) oppure utilizza il codice QR.

### 日本の

[www.alfalaval.com/bhe-manuals](http://www.alfalaval.com/bhe-manuals) からご自分の言語の取扱説明書をダウンロードするか、QRコードをお使ください。

### 한국의

[www.alfalaval.com/bhe-manuals](http://www.alfalaval.com/bhe-manuals) 에서 이 사용 설명서의 해당 언어 버전을 다운로드하거나 QR 코드를 사용하십시오.

### Lietuvos

Lejupielādējiet šīs rokasgrāmatas lokālo valodu versijas no vietnes [www.alfalaval.com/bhe-manuals](http://www.alfalaval.com/bhe-manuals) vai izmantojiet QR kodu.

### Latvijas

Atsīsiņskite šios instrukcijas versijas vietos kalba iš [www.alfalaval.com/bhe-manuals](http://www.alfalaval.com/bhe-manuals) arba pasinaudokite QR kodu.

### Nederlands

Download de lokale taalversies van de instructiehandleiding vanaf [www.alfalaval.com/bhe-manuals](http://www.alfalaval.com/bhe-manuals) of gebruik de QR-code.

### Norsk

Last ned denne instruksjonshåndboken på lokalt språk fra [www.alfalaval.com/bhe-manuals](http://www.alfalaval.com/bhe-manuals) eller bruk QR-koden.

### Polski

Pobierz lokalne wersje językowe tej instrukcji obsługi z [www.alfalaval.com/bhe-manuals](http://www.alfalaval.com/bhe-manuals) lub użyj kodu QR.

### Português

Descarregue as versões locais na sua língua deste manual de instruções a partir de [www.alfalaval.com/bhe-manuals](http://www.alfalaval.com/bhe-manuals) ou use o código QR.

### Português do Brasil

Faça download das versões deste manual de instruções no idioma local em [www.alfalaval.com/bhe-manuals](http://www.alfalaval.com/bhe-manuals) ou use o código QR.

### Românesc

Versiunile în limba locală ale acestui manual de instrucțiuni pot fi descărcate de pe [www.alfalaval.com/bhe-manuals](http://www.alfalaval.com/bhe-manuals) sau puteți utiliza codul QR.

### **Русский**

Руководство пользователя на другом языке вы можете загрузить по ссылке [www.alfalaval.com/bhe-manuals](http://www.alfalaval.com/bhe-manuals) или отсканировав QR-код.

### **Slovenski**

Prenesite različice uporabniškega priročnika v svojem jeziku s spletne strani [www.alfalaval.com/bhe-manuals](http://www.alfalaval.com/bhe-manuals) ali uporabite kodo QR.

### **Slovenský**

Miestne jazykové verzie tohto návodu na používanie si stiahnite z [www.alfalaval.com/bhe-manuals](http://www.alfalaval.com/bhe-manuals) alebo použite QR kód.

### **Svenska**

Ladda ned lokala språkversioner av denna bruksanvisning från [www.alfalaval.com/bhe-manuals](http://www.alfalaval.com/bhe-manuals) eller använd QR-koden.

### **中国**

从 [www.alfalaval.com/bhe-manuals](http://www.alfalaval.com/bhe-manuals) 或使用 QR 码下载此使用说明书的本地语言版本。

---

# Contents

|          |   |           |
|----------|---|-----------|
| <b>1</b> | <b>Preface</b> .....                          | <b>7</b>  |
| 1.1      | Intended use.....                             | 7         |
| 1.2      | Prior knowledge.....                          | 7         |
| 1.3      | Warranty conditions.....                      | 7         |
| 1.4      | Environmental compliance.....                 | 7         |
| <b>2</b> | <b>Safety</b> .....                           | <b>9</b>  |
| 2.1      | Safety considerations.....                    | 9         |
| 2.2      | Definitions of expressions.....               | 9         |
| 2.3      | Personal protective equipment.....            | 10        |
| <b>3</b> | <b>Description</b> .....                      | <b>11</b> |
| 3.1      | Function.....                                 | 11        |
| 3.2      | Name plates.....                              | 11        |
| <b>4</b> | <b>Installation</b> .....                     | <b>13</b> |
| 4.1      | Unpacking.....                                | 13        |
| 4.2      | Lifting.....                                  | 13        |
| 4.3      | Requirements.....                             | 14        |
| 4.4      | Mounting.....                                 | 16        |
| 4.5      | Installation in general.....                  | 18        |
| 4.6      | Installation as evaporator or condenser.....  | 20        |
| 4.7      | Leak test.....                                | 21        |
| <b>5</b> | <b>Operation</b> .....                        | <b>23</b> |
| 5.1      | Start-up.....                                 | 23        |
| 5.2      | Unit in operation.....                        | 24        |
| 5.3      | Shut-down.....                                | 27        |
| <b>6</b> | <b>Maintenance</b> .....                      | <b>29</b> |
| 6.1      | General guidelines regarding maintenance..... | 29        |
| 6.2      | Cleaning-In-Place.....                        | 29        |
| <b>7</b> | <b>Fault tracing</b> .....                    | <b>31</b> |
| 7.1      | Pressure drop problems.....                   | 31        |
| 7.2      | Heat transfer problems.....                   | 32        |
| <b>8</b> | <b>Storage</b> .....                          | <b>33</b> |



# 1 Preface

This manual provides information needed to install, operate and carry out the maintenance of the heat exchanger.

## 1.1 Intended use

The heat exchanger has been designed to meet the requirement for a wide range of heat transfer applications such as refrigeration, comfort heating, industrial heating and cooling, and the process industry.

## 1.2 Prior knowledge

The heat exchanger must be operated by individuals who have studied the instructions in this manual and have knowledge of the process. This includes knowledge of the precautions regarding media, pressures, the temperatures in the heat exchanger as well as specific precautions required for the process.

Maintenance and installation of the heat exchanger must be performed by individuals who have knowledge and authorization according to the local regulations. This includes performance work such as piping, welding and maintenance.

For maintenance work not described in this manual, please contact an Alfa Laval Representative for advice.

## 1.3 Warranty conditions

Unless altered by written agreement, Alfa Laval standard warranty applies.

## 1.4 Environmental compliance

Alfa Laval endeavours to perform its own operations as cleanly and efficiently as possible. Environmental aspects are taken into consideration when developing, designing, manufacturing, servicing and marketing the company's products.

Brazed Plate Heat Exchangers (BHE) consist of stainless steel channel plates and frame elements and bonded stainless steel or carbon steel connections. The brazing material consist of copper or nickel. Bolts, which are stainless steel or carbon steel with different surface treatments, are usually welded onto the product. Additionally, feet and lifting lugs can be mounted on demand

### Unpacking

Packing material consists of wood, plastics, cardboard boxes and, in some cases, metal straps.

Packing materials can be reused, recycled or used for energy recovery, according to local legislations.

### Disposal

Heat exchangers must be recycled according to relevant, local regulations. Any hazardous residues from the process liquid must be considered and dealt with in a properly. When in doubt, or in absence of local regulations, please contact the local Alfa Laval representative.

### **Restricted substances**

All heat exchangers are in compliance with REACH (Registration, Evaluation, Authorization and Restriction of Chemicals) and RoHS Directive.



## 2 Safety

### 2.1 Safety considerations

The plate heat exchanger shall be used and maintained in accordance with Alfa Laval's instructions in this manual. Incorrect handling of the plate heat exchanger may result in serious consequences with injuries to persons and/or property damage. Alfa Laval will not accept responsibility for any damage or injury resulting from not following the instructions in this manual.

The plate heat exchanger should be used in accordance with the specified configuration of material, media types, temperatures and pressure for your specific plate heat exchanger

### 2.2 Definitions of expressions

#### **WARNING** Type of hazard

WARNING indicates a potentially hazardous situation which, if not avoided, could result in death or serious injury.

#### **CAUTION** Type of hazard

CAUTION indicates a potentially hazardous situation which, if not avoided, may result in minor or moderate injury.

#### **NOTE**

NOTE indicates a potentially hazardous situation which, if not avoided, may result in property damage.



Safety

## 2.3 Personal protective equipment

### Protective shoes

A shoe with a reinforced toe cap to minimize foot injuries caused by dropped articles.



### Protective helmet

Any helmet designed to protect the head from accidental injury.



### Protective goggles

A pair of tight-fitting eyeglasses worn to protect the eyes from hazards.



### Protective gloves

Gloves that protects the hand from hazards.



Safety

## 3 Description

### 3.1 Function

The heat exchanger consists of a pack of corrugated metal plates with portholes for the input and output of the two separate fluids. The heat transfer between the two fluids takes place through the plates.

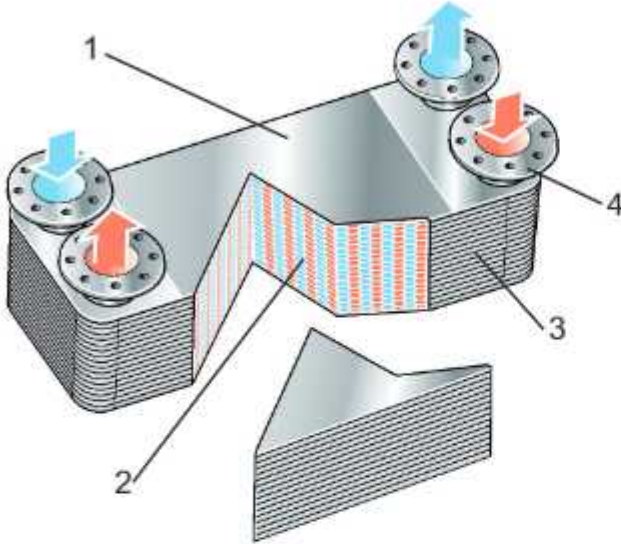

Figure 1: Function: Cover plate (1), corrugated plates (2), seal (3) and ports (4).

### 3.2 Name plates



**WARNING** Risk of damage to equipment.

The mechanical design pressures and temperatures are marked on the name plate.

The design temperatures refer to the temperature of the plate material. In the case of Gas-to-liquid plate heat exchangers (GL and GLX products) the gas inlet temperature may exceed the design temperatures provided there is sufficient coolant temperature and flow. The gas inlet temperature and flow rate must be according to the thermal data sheet provided by Alfa Laval for the specific installation.

The unit type, manufacturing number and year along with the pressure vessel details in accordance with applicable pressure vessel code can be found on the name plate. The name plate is fixed to the cover plate (usually on the same side as the connections).

Name plate differs depending on the type of pressure vessel approval.



## 4 Installation

All brazed units covered by Water Regulations Approval Scheme (WRAS) certifications are approved up to 100 °C on the Domestic Hot Water (DHW) side.

### 4.1 Unpacking

Carefully open the package containing the heat exchanger. Check that all items are included according to the specifications and that all parts are undamaged.

Before installing the heat exchanger, remove the plastic plugs or caps in the connections.

### 4.2 Lifting

#### WARNING

Never lift only by the connections or any of the studs. Use straps when lifting and place them according to the figure below.



Figure 2: Examples of lifting.

#### NOTE

When using lifting lugs, keep the angle of the straps as close as possible to 90° but never less than 60°.



**⚠ WARNING**

Be careful and keep clear of the heat exchanger during lifting to avoid personal injuries.

**⚠ WARNING**

Heat exchangers with large plate packs may be difficult to lift without lifting lugs because the center of gravity may cause the heat exchanger lean too much. If in doubt, use lifting lugs.



### 4.3 Requirements

**⚠ WARNING**

The heat exchanger must be installed and operated so that no risk of injury to personnel or damage to property.

**⚠ CAUTION**

Protective gloves should always be worn when handling the heat exchanger to avoid hand injuries caused by sharp edges.

**! NOTE**

Unless otherwise specified, product data for normal refrigerants, i.e. HFC and HCFC, are applicable to refrigeration applications. The manufacturer must be consulted before the heat exchanger is used for flammable, toxic or dangerous liquids (e.g. hydrocarbons). Relevant safety rules must be followed for handling such liquids. For further information, please refer to the supplier's website.

#### Foundation

Install on a foundation that will give enough support to the unit.

#### Protection against loads on connections during operation

The piping must be well supported so that no loads are transferred to the heat exchanger during operation. Also refer to [Mounting](#) on page 16.

### Connection loads at installation

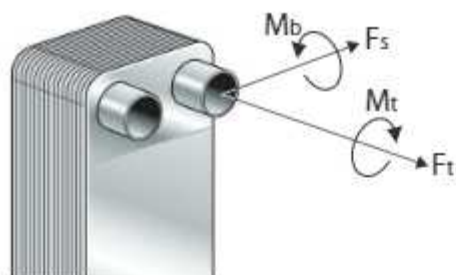

Figure 3: Connection loads.

With reference to definitions in figure, the loads during installation should not exceed the limits specified in table below.

### Maximum recommended connection loads during installation

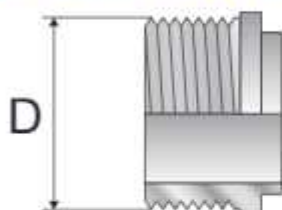

Figure 4: Outer diameter of the connection (D).

Table 1: Maximum recommended connection loads during installation

| Outer diameter, mm<br>(inch) | Tension force    | Bending moment      | Shear force <sup>1</sup> | Torque              |
|------------------------------|------------------|---------------------|--------------------------|---------------------|
|                              | $F_t$ , kN (lbf) | $M_b$ , Nm (lbf·ft) | $F_a$ , kN (lbf)         | $M_t$ , Nm (lbf·ft) |
| 15 - 28 (0.6 - 1.1")         | 2.4 (539)        | 14 (10.3)           | 0.7 (157)                | 38 (28.0)           |
| 29 - 35 (1.1 - 1.4")         | 4.0 (899)        | 45 (33.2)           | 1.2 (269)                | 120 (88.5)          |
| 36 - 45 (1.4 - 1.8")         | 6.5 (1461)       | 110 (81.1)          | 2.5 (562)                | 240 (177.0)         |
| 46 - 55 (1.8 - 2.2")         | 7.0 (1573)       | 120 (88.5)          | 4.8 (1079)               | 440 (324.5)         |
| 56 - 76 (2.2 - 3.0")         | 12.0 (2697)      | 250 (184.4)         | 5.2 (1169)               | 600 (442.5)         |
| 77 - 99 (3.0 - 3.9")         | 13.0 (2922)      | 310 (228.6)         | 5.8 (1303)               | 1200 (885.0)        |
| 100 - (3.9" - )              | 28.0 (6294)      | 800 (590)           | 5.8 (1303)               | 2500 (1843)         |

<sup>1</sup> Shear force ( $F_s$ ) is calculated assuming that the force is applied at the end of the longest standard connection.

## 4.4 Mounting

It is recommended to mount the heat exchanger on the floor, on feet or on the wall.



Larger heat exchangers should be secured with support mountings (ordered as accessory) intended for a specific heat exchanger, or be secured with straps or by means of mounting bolts.

### ! NOTE

Regardless of the mounting method minimize the pipe loads at installation.

Maximum tightening torques for the mounting bolts according to table below.

| Bolt dimension         | Torque |        |
|------------------------|--------|--------|
|                        | Nm     | lbf·ft |
| M5                     | 2.3    | 1.7    |
| M6                     | 3.8    | 2.8    |
| M8                     | 9.5    | 7.0    |
| M8 (Extra small units) | 8.0    | 5.9    |
| M10                    | 19.0   | 14.0   |
| M12                    | 33.0   | 24.3   |
| UNC 1/4"               | 3.8    | 2.8    |
| UNC 5/16"              | 8.6    | 6.4    |
| UNC 3/8"               | 15.6   | 11.5   |

In a rigid pipe system, small heat exchangers can be suspended directly in the pipework. To avoid vibrations, use anti-vibration mounting according to picture below.





### Recommendations for GL products

It is recommended to mount the heat exchanger on the floor, on feet or on the wall. The heat exchanger can be installed horizontally or vertically.

#### NOTE

For condensing applications it is recommended to install the unit vertically with the gas flow from top to down. The condensation outlet must be at the lowest point to avoid build-up of condensate in the heat exchanger.

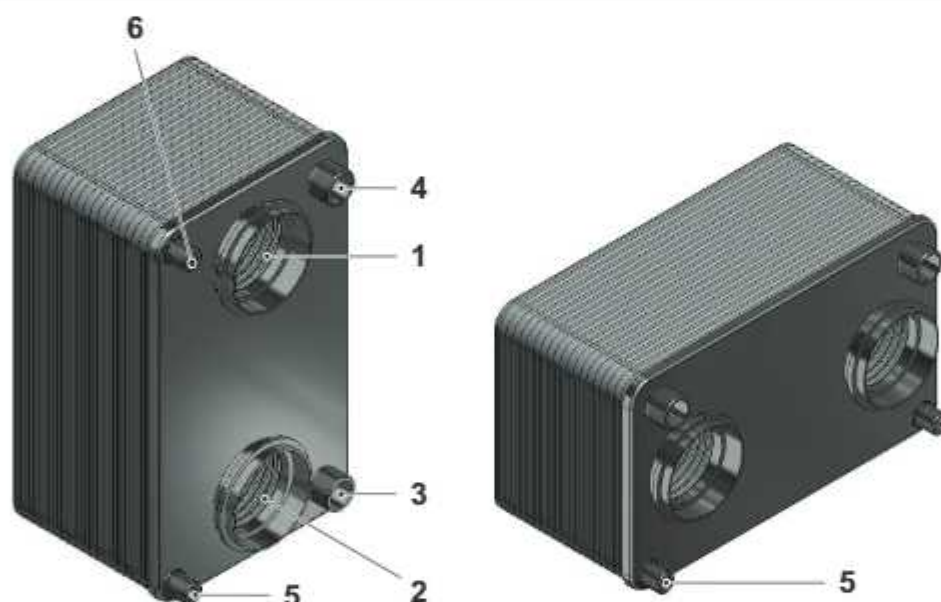

1. Gas inlet
2. Gas outlet
3. Water inlet
4. Water outlet
5. Condensation outlet
6. CIP outlet

#### NOTE

For condensing applications for the GLX units the installation must be vertical with the gas flow from top to down to collect the condensate below the heat exchanger.

#### NOTE

An external casing is required for GLX units to achieve correct functionality.



## 4.5 Installation in general

### ⚠ WARNING

Safety valves must be installed according to pressure vessel regulations.

### ! NOTE

Before connecting any piping, make sure all foreign objects have been flushed out of the system.

The plate heat exchanger must be installed with equipment that protects it against pressures and temperatures outside the approved minimum and maximum values shown on the name plate.

For vibration risks, install anti-vibration mountings as shown in picture for rigid pipe system in section [Mounting](#).

Normally the heat exchanger is connected so that the media flows through the heat exchanger in opposite directions (in counter-current flow) and in most cases this provides the best heat transfer performance.

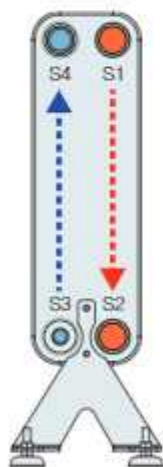

Take into account the risk of fire during installation, i.e. bear in mind the distance from flammable substances.

### Connections

Soldering or welding connections must be used when using a flammable refrigerant.

**Threaded connections** – Use a torque wrench when connecting the pipe and observe the specified limits. Refer to table “Maximum recommended connection loads during installation” in section [Requirements](#).

**Brazed connections** – Clean by rubbing down and degreasing the various surfaces. Use the correct brazing temperature and brazing metal grade.

**Welded connections** – To minimize the heat impact of the heat exchanger it is recommended to use TIG or MIG welding methods. Preparation for welding: Grind inside and outside of the pipe and, if bevelled, also the bevelled edge at least 25 mm from the pipe edge and inward. This should be done to avoid contamination of copper in the welded area, which might cause the weld to crack.

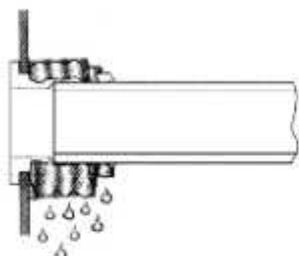

**! NOTE**

Before connecting the heat exchanger to the system consider valve set-up and access points for example to be prepared to perform cleaning.

**! NOTE**

Protect the heat exchanger from overheating by wrapping a piece of wet cloth around the connection while soldering or welding. Excessive heating could melt the internal soldering metal inside the heat exchanger.

## 4.6 Installation as evaporator or condenser

In applications where a phase change of media occurs, the heat exchanger must be installed vertically.

For refrigeration applications – Figure A shows the installation of an evaporator, where the connections may be either on the front or on the rear. Figure B shows a condenser.

- Use an anti-freeze thermostat and flow monitor to ensure a constant water flow before, during, and at least two minutes after the compressor has been running.
- Avoid "pump-down", i.e. emptying the evaporator by running the compressor after shut-down until a preset refrigerant pressure is reached. The temperature could then drop below the brine freezing point, which could damage the evaporator.
- Use a flow switch and a low-pressure switch.
- Make sure only media from the heat exchanger can pass the flow switch. The low-pressure switch should assure a minimum pressure drop of 5 - 10 kPa (0.73 - 1.45 PSI).

Heat exchanger with a refrigerant distribution system should be mounted with the distributor at the bottom.

Typical installation of single circuit:

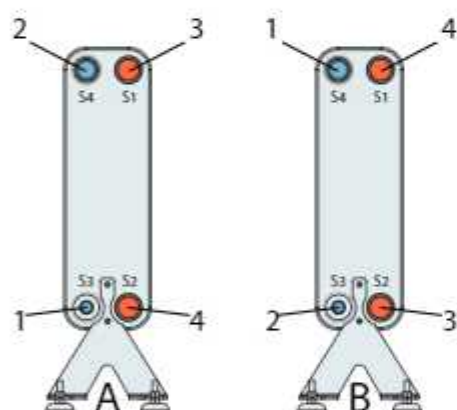

Figure 5: Single circuit: A evaporator; B condenser. 1.Refrigerant inlet  
2.Refrigerant outlet 3.Water/Brine inlet 4.Water/Brine outlet

For an evaporator, the pipe should be straight (at least 150 mm / 5.9 inch length) between the expansion valve and refrigerant inlet. Avoid using pipe elbows between the expansion valve and the refrigerant inlet.

The heat exchanger could be of single or dual circuit type. Flow direction of a single circuit heat exchanger is normally parallel, while on dual circuit heat exchanger could be diagonal or parallel. Make sure that the heat exchanger is installed correctly according to the current flow direction for the heat exchanger. For detailed information about flow direction see the name plate.

Connections can be placed in the front or rear of the heat exchanger. Typical installation of a dual circuit heat exchanger as an evaporator:

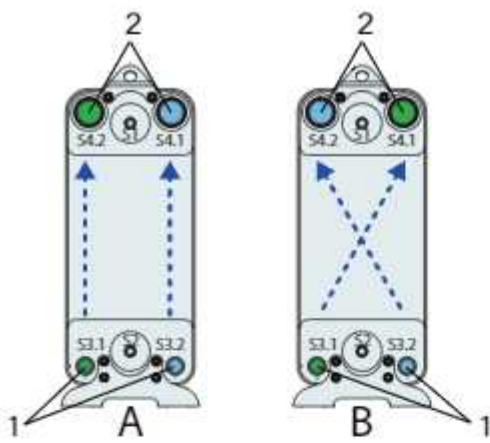

Figure 6: Dual circuit: A is parallel flow; B is diagonal flow. 1.Refrigerant inlet  
2.Refrigerant outlet Water/Brine inlet and outlet are typically positioned on the rear side.

#### 4.7 Leak test

Perform leakage test of the connections before placing the heat exchanger in operation.



## 5 Operation

### 5.1 Start-up

#### ! NOTE

If several pumps are included in the system, make sure you know which one should be activated first.

#### ! NOTE

Adjustments of flow rates should be made slowly in order to avoid the risk of water hammer.

Water hammer is a short-lasting pressure peak that can appear during start-up or shut-down of a system, which causing liquids to travel along a pipe as a wave at the speed of sound. This can cause considerable damage to the equipment.

- 1 Check that the inlet valve (2) is closed between the pump and the unit controlling the system flow rate.  
Inlet valve (2, 3) for both fluids should be closed, the outlet valves (1, 4) opened and the vent valve (5, 6) closed.

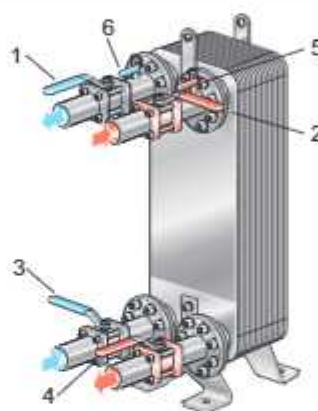

- 2 If there is a outlet valve (4), make sure that it is fully open.
- 3 Open the vent valve (5) and start the pump.
- 4 Open the inlet valve (2) slowly.
- 5 When all air is expelled, close the vent valve (5).
- 6 Repeat steps 1–5 for the second media.

## 5.2 Unit in operation

### NOTE

Adjustments of flow rates should be made slowly in order to protect the system against sudden and extreme variations of temperature and pressure.

During operation, check that:

- the inlet temperatures do not exceed the limits stated on the name plate.
- there are no leakages from the connections.

If it is agreed with Alfa Laval that the gas inlet temperature in a Gas-to-liquid plate heat exchanger can exceed the temperature stated on the name plate check that the coolant temperature and flow are at the correct values. The coolant temperature must not increase and / or the coolant flow decrease from the values given in the thermal data sheet.

### Protection against connection loads

Make sure that the heat exchanger is fastened to avoid or minimize connection loads during operation.

### Protection against freezing

Bear in mind the risk of freezing at low temperatures. Heat exchangers that are not in operation should be emptied and blown dry whenever there is a risk of freezing.

Heat exchangers operating with freezing temperatures shall be properly insulated with the insulation tight to the surface of the heat exchanger to avoid humid air to freeze. Contact Alfa Laval representative for further clarification.

### NOTE

To avoid damage due to freezing, the medium used must include an anti-freeze agent when operating conditions are below 5 °C (41 °F) and/or when the evaporating temperature is below 1 °C (34 °F).

### Protection against clogging

Use a filter as protection against the possible occurrence of foreign particles. If you have any doubt concerning the maximum particle size, please consult your Alfa Laval Representative.

### Protection against over-heating and boiling

### WARNING

Make sure the pressure at the coolant outlet is high enough to avoid boiling.

The heat exchanger must always have the cooling fluid circulating fully before the hot gas enters the heat exchanger.



### Protection against thermal or/and pressure fatigue

Sudden temperature and pressure changes could cause fatigue damage to the heat exchanger. Therefore, the following must be taken into consideration to ensure that the heat exchanger operates without fluctuating pressures/temperatures.

#### WARNING

The heat exchanger is not intended for cyclic processes, please contact an Alfa Laval Representative for advice.

- Locate the temperature sensor as close as possible to the outlet from the heat exchanger.
- Choose valves and regulation equipment which give stable temperatures/pressures for the heat exchanger.
- To avoid water hammer, quick-closing valves must not be used, e.g. on/off valves.
- In automated installations, stopping and starting of the pumps and actuation of valves must be programmed so that the amplitude and frequency of the pressure variation are as low as possible.

### Protection against corrosion

#### CAUTION

Do not use the heat exchanger for de-ionized water as this media can chemically affect the copper brazing material.

Do not use the heat exchanger for installations with galvanized pipes that chemically or electrochemically could affect or be affected by the stainless steel plates and the copper brazing material.

#### NOTE

Copper may generate corrosion in installation with mixed materials.

#### CAUTION

Avoid ammonia or other media that could be corrosive to stainless steel and copper.

#### Recommended limits for Chloride ions, Cl<sup>-</sup> at pH 7.5 <sup>1 2</sup>

|                   | Alloy 304 | Alloy 316 |
|-------------------|-----------|-----------|
| at 25 °C / 77 °F  | 100 ppm   | 1000 ppm  |
| at 65 °C / 149 °F | 50 ppm    | 200 ppm   |
| at 80 °C / 176 °F | 20 ppm    | 100 ppm   |

<sup>1</sup> Halogens, e.g. bromides and fluorides may also cause corrosion.

<sup>2</sup> Lower levels of chloride ions may cause corrosion due to other factors.

### **Insulation**

If the heat exchanger will be operated at very hot or very cold temperature, take protective actions, such as insulation, to avoid injuries. Be certain to follow all local regulations.

Heating and cooling insulations are available as accessories.

Be aware that temperature limits of insulation and the heat exchanger can be different.

## 5.3 Shut-down

**! NOTE**

If several pumps are included in the system, make sure you know which one should be stopped first.

- 1 Slowly reduce the flow rate in order to avoid water hammer.
- 2 When the valve is closed, stop the pump.
- 3 Repeat steps 1–2 for the other medium/media.
- 4 If the heat exchanger is shut down for a long period, it should be drained.

Also, drain the heat exchanger if the process is shut down and the ambient temperature is below the freezing temperature of the media. Depending on the media processed, rinse and dry the heat exchanger and its connections.



## 6 Maintenance

Cleaning can improve the performance of the heat exchanger. Cleaning intervals depends on factors such as media and temperatures.

### 6.1 General guidelines regarding maintenance

#### Plate Sheet material

Stainless steel can corrode. Chloride ions are hazardous.

Avoid cooling brines containing chloride salts as NaCl and, most harmful, CaCl<sub>2</sub>.

#### Chlorine as a growth inhibitor

##### ! NOTE

Chlorine, commonly used as a growth inhibitor in cooling water systems, reduces the corrosion resistance of stainless steels.

Chlorine weakens the passive layer of these steels making them more susceptible to corrosion. This is dependent on exposure time and concentration of chlorine.

In every case where the chlorination of the heat exchanger cannot be avoided, consult an Alfa Laval Representative for advice.

### 6.2 Cleaning-In-Place

Cleaning-In-Place (CIP) equipment permits cleaning of the heat exchanger.



CIP performs:

- By regular CIP, the dissolution of fouling helps to restore the original thermal performance of the unit.
- The passivating effect by the CIP procedure can help to maintain the original corrosion resistance of the plate material.

Follow the instructions of the CIP equipment.

Consult an Alfa Laval representative for appropriate advice on selecting CIP equipment.

For detailed information regarding Cleaning liquids and procedure, refer to the Alfa Laval Cleaning procedures manual.

Type of cleaning:

- AlfaCaus cleaning removes organic deposits. During the process it is important to control the pH value and the recommended pH value is 7.5 - 10. Higher pH values increase risk of the copper oxidizing.
- AlfaNeutra for neutralization of cleaning liquids before draining and flushing the unit with potable water.
- AlfaPhos cleaning removes inorganic deposits such as limestone.

Rinse well with fresh water after cleaning.

 **WARNING**

Use proper protective equipment, such as safety boots, safety gloves and eye protection, when using cleaning agents.



 **WARNING**

Corrosive cleaning liquids can cause serious injuries to skin and eyes



 **CAUTION**

Make sure that the handling of residuals after using cleaning liquids follows the local environmental regulations.

## 7 Fault tracing

### 7.1 Pressure drop problems

If the pressure drop has increased.

| Action   |   |
|--|---|
| 1. Check that all valves are open including non-return valves.   |   |
| <ul style="list-style-type: none"> <li>• Measure the pressure and the flow rate directly in front of the inlet and after the outlet of the heat exchanger. For viscous media use a membrane manometer with a diameter of at least 30 mm.</li> <li>• Measure or estimate the flow rate if possible. A bucket and a watch showing seconds may be sufficient for small flow rates. For larger flow rates, use a flowmeter.</li> </ul> |   |
| Correction   |   |
| YES  | - |
| NO   | - |

| Action   |  |
|--|--|
| 2. Compare the pressure drop observed with the specified flow rate (see data print-out). Is the pressure drop higher than specified? |  |
| Correction   |  |
| YES  | Check the temperature program, see step 3  |
| NO   | If the pressure drop corresponds to the specifications, there is no need for action. If the pressure drop is lower than specified, the pump capacity is probably too small or the observation may be wrong. See pump instruction manual. |

| Action  |   |
|---|---|
| 3. Check the thermometer readings. Do the readings correspond to those specified? |   |
| Correction  |   |
| YES   | The heat transfer surface is probably clean enough, but the inlet to the heat exchanger may be clogged by some objects. Check the port area.  |
| NO  | Heat transfer is obviously dropping below specifications, because of deposits on the heat transfer surface, which at the same time also increases the pressure drop, since the passage becomes narrower. If a Cleaning-In-Place (CIP) system is available, follow the instructions and use it to wash out the deposits. |

## 7.2 Heat transfer problems

The heat transfer capacity is dropping.

| Action   |  |
|--|--|
| <p>1. Measure temperatures at inlets and outlets. Also measure flow rates on both media, if possible. On at least one of the media, both temperatures and the flow rate must be measured.</p> <ul style="list-style-type: none"> <li>• Check to see if the transferred amount of heat energy corresponds to the specifications.</li> <li>• If great precision is important, it will be necessary to use laboratory thermometers with an accuracy of 0.1 °C, and also to use the best equipment available for flow measurement. Has the heat transfer capacity of the unit dropped below specified values?</li> </ul> |  |
| Correction   |  |
| YES  | Clean the heat transfer surface. Use the Cleaning-In-Place (CIP) system. |
| NO   | -  |



## 8 Storage

Alfa Laval delivers the heat exchanger ready for operation, unless agreed otherwise. Keep the plate heat exchanger in the packing box until it is ready to be installed.

If there is any uncertainty with regard to the storage of the heat exchanger, please consult an Alfa Laval Representative.

For longer storage periods, keep the heat exchanger in a protective environment away from corrosive substances and dust which may affect its performance.

Keep the plastic plugs or caps for the connections in place during storage.