

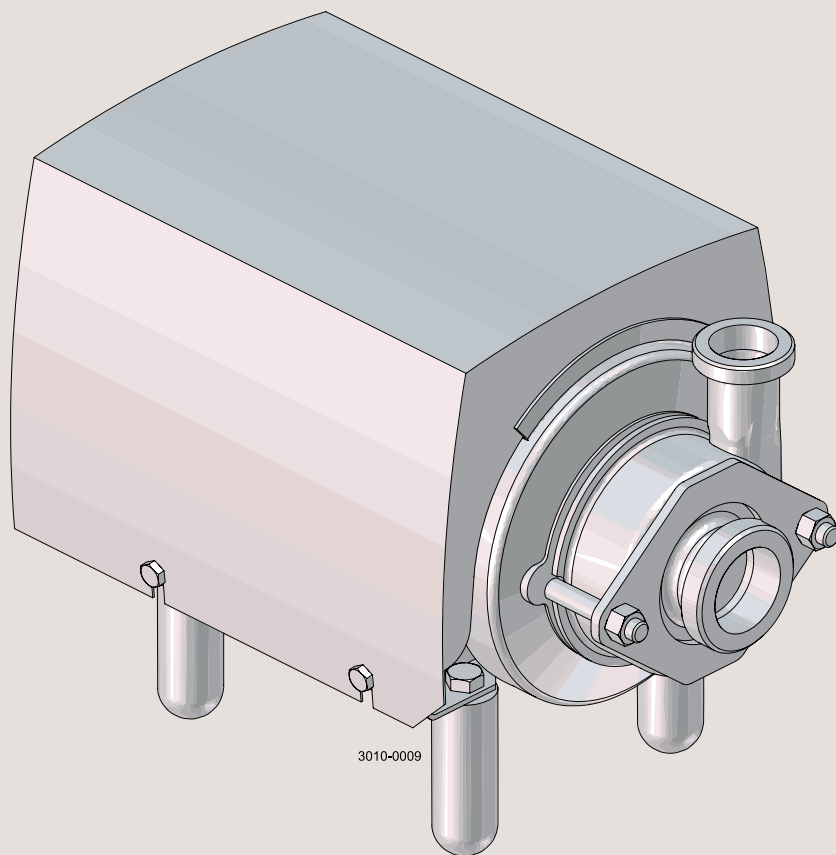

# Instruction Manual

## FM-OS Centrifugal Pump



100002849-EN5 2022-10

Original manual



# Table of contents

The information herein is correct at the time of issue but may be subject to change without prior notice

<b>1. Declarations of Conformity</b>	<b>4</b>
<b>2. Safety</b>	<b>6</b>
2.1. Important information	6
2.2. Warning signs	6
2.3. Safety precautions	7
<b>3. Installation</b>	<b>9</b>
3.1. Unpacking/delivery	9
3.2. Installation	10
3.3. Pre-use check	12
3.4. Recycling information	13
<b>4. Operation</b>	<b>14</b>
4.1. Operation/control	14
4.2. Trouble shooting	15
4.3. Recommended cleaning	16
<b>5. Maintenance</b>	<b>17</b>
5.1. General maintenance	17
5.2. Dismantling - single shaft seal	19
5.3. Dismantling - flushed shaft seal	20
5.4. Assembly - single shaft seal	21
5.5. Assembly - flushed shaft seal	22
5.6. Assembly - new shaft	22
<b>6. Technical data</b>	<b>23</b>
6.1. Technical data	23
6.2. Torque specifications	24
6.3. Weight (kg)	24
6.4. Noise emission	25
<b>7. Parts list and service kits</b>	<b>27</b>
7.1. Drawings	27
7.2. FM-OS Centrifugal pump, single shaft seal	28
7.3. FM-OS Centrifugal pump, flushed shaft seal	30

# 1 Declarations of Conformity

## EU Declaration of Conformity

The Designated Company

Alfa Laval Kolding A/S, Albuen 31, DK-6000 Kolding, Denmark, +45 79 32 22 00

Company name, address and phone number

Hereby declare that

Pump

Designation

FM-OS

Type

Serial number from 10.000 to 1.000.000

is in conformity with the following directives with amendments:

- Machinery Directive 2006/42/EC
- RoHS EU Directive 2011/65/EU and amendments

The person authorised to compile the technical file is the signer of this document.

Global Product Quality Manager

Title

Lars Kruse Andersen

Name

Kolding, Denmark

Place

2022-10-01

Date (YYYY-MM-DD)

Signature

This Declaration of Conformity replaces Declaration of Conformity dated 2013-12-03



# 1 Declarations of Conformity

## UK Declaration of Conformity

The Designated Company

Alfa Laval Kolding A/S, Albuen 31, DK-6000 Kolding, Denmark, +45 79 32 22 00

Company name, address and phone number

Hereby declare that

Pump

Designation

FM-OS

Type

Serial number from 10.000 to 1.000.000

is in conformity with the following directives with amendments:

- The Supply of Machinery (Safety) Regulations 2008
- The Restriction of the Use of Certain Hazardous Substances in Electrical and Electronic Equipment Regulations 2012

Signed on behalf of: Alfa Laval Kolding A/S

Global Product Quality Manager

Title

Lars Kruse Andersen

Name

Kolding, Denmark

Place

2022-10-01

Date (YYYY-MM-DD)

Signature

DoC Revison\_01\_102022

**UK  
CA**



## 2 Safety

---

*Unsafe practices and other important information are emphasised in this manual.*

*Warnings are emphasised by means of special signs.*

***Always read the manual before using the pump!***

---

### 2.1 Important information

---

#### **WARNING**

Indicates that special procedures must be followed to avoid serious personal injury.

#### **CAUTION**

Indicates that special procedures must be followed to avoid damage to the pump.

#### **NOTE**

Indicates important information to simplify or clarify procedures.

---

### 2.2 Warning signs

---



General warning:



Dangerous electrical voltage:



Caustic agents:

---

All warnings in this manual are summarised on this page.

Pay special attention to the instructions below so that serious personal injury and/or damage to the pump are avoided.

### 2.3 Safety precautions

#### Installation:

**Always** read the technical data thoroughly. (See chapter 6 Technical data)  
**Always** use a lifting crane when handling the pump.



#### Pump without impeller screw:

**Always** remove the impeller before checking the direction of rotation.  
**Never** start the pump if the impeller is fitted and the pump casing is removed.

#### Pump with Impeller screw:

**Never** start in the wrong direction of rotation with liquid in the pump.  
**Always** have the pump electrically connected by authorised personnel. (See the motor instruction)



#### Operation:

**Always** read the technical data thoroughly. (See chapter 6 Technical data)  
**Never** touch the pump or the pipelines when pumping hot liquids or when sterilising.  
**Never** run the pump with both the suction side and the pressure side blocked.  
**Never** run the pump when partially installed or not completely assembled  
**Necessary** precautions must be taken if leakage occurs as this can lead to hazardous situations.



**Always** handle lye and acid with great care.  
**Never** use the pump for products not mentioned in Alfa Laval pump selection program.  
The Alfa Laval pump selection program can be acquired from your local Alfa Laval sales company.



#### Maintenance:

**Always** read the technical data thoroughly. (See chapter 6 Technical data)  
**Never** service the pump when it is hot.  
**Never** service the pump if pressurised.  
**Always** use Alfa Laval genuine spare parts.



#### Motors with grease nipples:

Remember lubrication according to information plate/label on the motor.

**Always** disconnect the power supply when servicing the pump.



#### Transportation:

##### Transportation of the pump or the pump unit:

**Never** lift or elevate in any way other than as described in this manual  
**Always** drain the pump head and accessories of any liquid

## 2 Safety

---

*All warnings in this manual are summarised on this page.*

*Pay special attention to the instructions below so that serious personal injury and/or damage to the pump are avoided.*

---

**Always** ensure that no leakage of lubricants can occur

**Always** transport the pump in its upright position

**Always** ensure that the unit is securely fixed during transportation

**Always** use original packaging or similar during transportation

---



### 3.1 Unpacking/delivery

---

#### Step 1

##### **CAUTION**

Alfa Laval cannot be held responsible for incorrect unpacking.

#### **Check the delivery for:**

1. Complete pump.
  2. Delivery note.
  3. Instruction manual.
  4. Motor instructions.
  5. Test certificate, IF ORDERED!
- 

#### Step 2

Remove any possible packing materials from the inlet and the outlet.

Avoid damaging the inlet and the outlet.

Avoid damaging the connections for flushing liquid, if supplied.

---

#### Step 3

Inspect the pump for visible transport damage.

---

#### Step 4

Always remove the shroud, if fitted, before lifting the pump.

---

## 3 Installation

Study the instructions carefully and pay special attention to the warnings! Always check the pump before operation.  
- See pre-use check in section 3.3 Pre-use check.

### 3.2 Installation

#### Step 1



**Always** read the technical data thoroughly. (See chapter 6 Technical data)



**Always** have the pump electrically connected by authorised personnel. (see the motor instructions).

#### CAUTION

Alfa Laval cannot be held responsible for incorrect installation.

#### WARNING:

Alfa Laval recommends the installation of lockable repair breaker. If the repair breaker is to be used as an emergency stop, the colours of the repair breaker must be red and yellow.

#### Caution:

The pump does not prevent back flow when intentionally or unintentionally stopped. If back flow can cause any hazardous situations, precautions must be taken e.g. check valve to be installed in the system preventing that described above.

#### Note

In case of shaft seal leakage, the media will drip from the slot in the bottom of the adaptor. In case of shaft seal leakage, Alfa Laval recommends placing a drip tray underneath the slot to collect the leakage.

#### Step 2

Ensure that there is sufficient clearance around the pump.

#### Step 3

Check that the flow direction is correct.

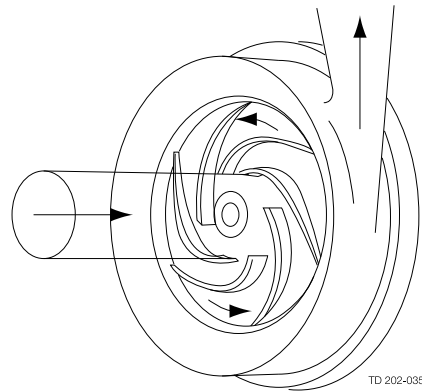

#### Step 4

1. Ensure that the pipelines are routed correctly.
2. Ensure that the connections are tight.

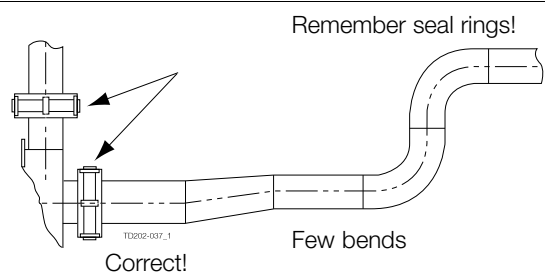

*Study the instructions carefully and pay special attention to the warnings! Always check the pump before operation.*  
*- See pre-use check in section 3.3 Pre-use check.*

---

### **Step 5**

Avoid stresses to the pump.

Pay special attention to:

- Vibrations.
  - Thermal expansion of the tubes.
  - Excessive welding.
  - Overloading of the pipelines.
- 

Risk of damage

## 3 Installation

---

*Study the instructions carefully and pay special attention to the warnings!*  
*Check the direction of rotation of the impeller before operation.*  
*- See the indication label on the pump.*

---

### 3.3 Pre-use check

---

#### Step 1



**Always** remove the impeller before checking the direction of rotation.



**Never** start the pump if the impeller is fitted and the pump casing is removed.

---

#### Step 2

Dismantle the pump in accordance with instructions in section 5.2 for single shaft seal and 5.3 for flushed shaft seal.

---

#### Step 3

1. Start and stop the motor momentarily.
  2. Ensure that the direction of rotation of the stub shaft (7) is anticlockwise as viewed from the inlet side.
- 

See the indication label!

#### Step 4

Assemble the pump in accordance with instructions in section 5.4 for single shaft seal and 5.5 for flushed shaft seal.

---

### 3.4 Recycling information

---

- **Unpacking**

- Packing material consists of wood, plastics, cardboard boxes and in some cases metal straps.
- Wood and cardboard boxes can be reused, recycled or used for energy recovery.
- Plastics should be recycled or burnt at a licensed waste incineration plant.
- Metal straps should be sent for material recycling.

- **Maintenance**

- During maintenance, oil and wear parts in the machine are replaced.
- All metal parts should be sent for material recycling.
- Worn out or defective electronic parts should be sent to a licensed handler for material recycling.
- Oil and all non-metal wear parts must be taken care of in accordance with local regulations.

- **Scrapping**

- At end of use, the equipment must be recycled according to relevant, local regulations. Beside the equipment itself, any hazardous residues from the process liquid must be taken into consideration and dealt with in a proper manner. When in doubt, or in the absence of local regulations, please contact your local Alfa Laval sales company.
-

## 4 Operation

Study the instructions carefully and pay special attention to the warnings!

### 4.1 Operation/control

#### Step 1



**Always** read the technical data thoroughly. See chapter 6 Technical data

#### CAUTION

Alfa Laval cannot be held responsible for incorrect operation/control.

#### Step 2



**Never** touch the pump or the pipelines when pumping hot liquids or when sterilising.

**Danger of burns!**

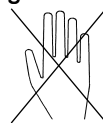

#### Step 3



**Never** run the pump with both the suction side and the pressure side blocked.

**Explosion danger!**  
=> See the warning label!

#### Step 4

#### CAUTION

The shaft seal must not run dry.

#### CAUTION

**Never** throttle the inlet side.

#### Step 5

#### Flushed shaft seal:

1. Connect the inlet of the flushing liquid correctly.
2. Regulate the water supply correctly.
3. Observe the steam data.

O: Free outlet

I: Inlet

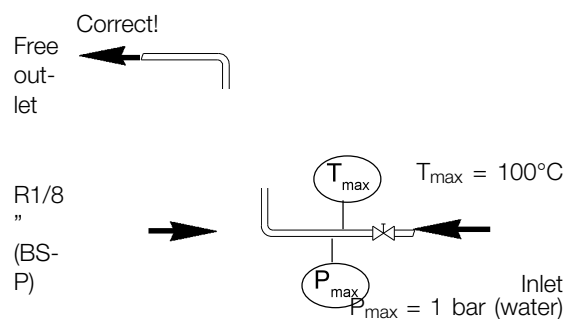

#### Step 6

#### Control:

Reduce the capacity and the power consumption by means of:

- Throttling the pressure side of the pump.
- Reducing the impeller diameter.
- Reducing the speed of the motor.

*Pay attention to possible faults.  
Study the instructions carefully.*

## 4.2 Trouble shooting

### NOTE!

Study the maintenance instructions carefully before replacing worn parts. - See section 5.1 General maintenance

Problem	Cause/result	Remedy
Overloaded motor	<ul style="list-style-type: none"> <li>- Pumping of viscous liquids</li> <li>- Pumping of liquids with high density</li> <li>- Low outlet pressure (counter pressure)</li> <li>- Lamination of precipitates from the liquid</li> </ul>	<ul style="list-style-type: none"> <li>- Larger motor or smaller impeller</li> <li>- Higher counter pressure (throttling)</li> <li>- Frequent cleaning</li> </ul>
Cavitation: <ul style="list-style-type: none"> <li>- Damage</li> <li>- Pressure reduction (sometimes to zero)</li> <li>- Increasing of the noise level</li> </ul>	<ul style="list-style-type: none"> <li>- Low inlet pressure</li> <li>- High liquid temperature</li> </ul>	<ul style="list-style-type: none"> <li>- Increase the inlet pressure</li> <li>- Reduce the liquid temperature</li> <li>- Reduce the pressure drop before the pump</li> <li>- Reduce speed</li> </ul>
Leaking shaft seal	<ul style="list-style-type: none"> <li>- Dry run</li> <li>- Incorrect rubber grade</li> <li>- Abrasive particles in the liquid</li> </ul>	Replace: All wearing parts  If necessary: <ul style="list-style-type: none"> <li>- Change rubber grade</li> <li>- Select stationary and rotating seal ring in silicon carbide/silicon carbide</li> </ul>
Leaking O-ring seals	Incorrect rubber grade	Change rubber grade

## 4 Operation

The pump is designed for cleaning in place (CIP). CIP = Cleaning In Place.  
Study the instructions carefully and pay special attention to the warnings!  
NaOH = Caustic soda.  
HNO<sub>3</sub> = Nitric acid.

### 4.3 Recommended cleaning

#### Step 1



**Always** handle lye and acid with great care.

**Caustic danger!**



Always use rubber gloves!



Always use protective goggles!

#### Step 2



**Never** touch the pump or the pipelines when sterilising.

**Danger of burns!**

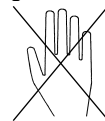

#### Step 3

**Examples of cleaning agents:** Use clean water, free from chlorides.

1. 1% by weight NaOH at 70°C (158°F).

1 kg (2.2 lb) NaOH + 100 l (26.4 gal) water = Cleaning agent.

2.2 l (0.6 gal) 33% NaOH + 100 l (26.4 gal) water = Cleaning agent.

2. 0.5% by weight HNO<sub>3</sub> at 70°C (158°F).

0.7 l (0.2 gal) 53% HNO<sub>3</sub> + 100 l (26.4 gal) water = Cleaning agent.

1. Avoid excessive concentration of the cleaning agent  
⇒ Dose gradually!
2. Adjust the cleaning flow to the process.  
Sterilisation of milk/viscous liquids  
⇒ Increase the cleaning flow!

#### Step 4



**Always** rinse well with clean water after using a cleaning agent.

#### NOTE

The cleaning agents must be stored/disposed of in accordance with current regulations/directives.

**Always rinse!**

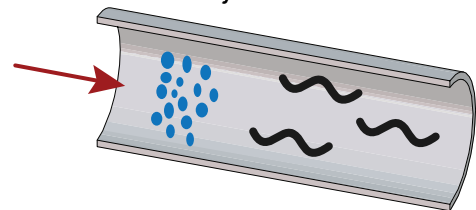

Clean water

Cleaning agent

3004-0033



Maintain the pump carefully. Study the instructions carefully and pay special attention to the warnings!  
Always keep spare shaft seals and rubber seals in stock.  
See separate motor instructions.  
Check the pump for smooth operation after service.

---

### 5.1 General maintenance

---

#### Step 1



**Always** read the technical data thoroughly. (See chapter 6 Technical data)



**Always** disconnect the power supply when servicing the pump.

#### NOTE

All scrap must be stored/discharged in accordance with current rules/directives.

---

#### Step 2



**Never** service the pump when it is hot.

**Danger of burns!**

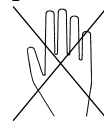

#### Step 3



**Never** service the pump with pump and pipelines under pressure.

Atmospheric pressure  
required!

#### CAUTION

Fit the electrical connections correctly if they have been removed from the motor during service. (see 3.3 Pre-use check)

#### CAUTION

Pay special attention to the warnings!

---

#### Step 4

##### Recommended spare parts:

Order service kits from the service kits list  
See chapter 7 Parts list and service kits

##### Ordering spare parts

Contact your local Alfa Laval sales company.

#### Note:

If the pump is supplied with FEP O-rings, Alfa Laval recommends that the casing O-ring is replaced during maintenance of the pump.

## 5 Maintenance

Maintain the pump carefully. Study the instructions carefully and pay special attention to the warnings!  
 Always keep spare shaft seals and rubber seals in stock.  
 See separate motor instructions.  
 Check the pump for smooth operation after service.

	Shaft seal	Rubber seals	Motor bearings
Preventive maintenance	<b>Replace after 12 months:</b> (one-shift) Complete shaft seal	Replace when replacing the shaft seal	
Maintenance after leakage (leakage normally starts slowly)	<b>Replace at the end of the day:</b> Complete shaft seal	Replace when replacing the shaft seal	
Planned maintenance	<ul style="list-style-type: none"> <li>- Regular inspection for leakage and smooth operation</li> <li>- Keep a record of the pump</li> <li>- Use the statistics for inspection planning</li> </ul> <b>Replace after leakage:</b> Complete shaft seal	Replace when replacing the shaft seal	Yearly inspection is recommended <ul style="list-style-type: none"> <li>- Replace complete bearing if worn</li> <li>- Ensure that the bearing is axially locked (See motor instructions)</li> </ul>
Lubrication	<b>Before fitting</b> Lubricate the O-rings with silicone grease or silicone oil	<b>Before fitting</b> Lubricate with silicone grease or silicone oil	See section

### Pre-use check CAUTION!

Fit the electrical connections correctly if they have been removed from the motor during service. (See 3.3 Pre-use check).

### Pay special attention to warnings!

1. Start and stop the motor momentarily.
2. Ensure that the pump operates smoothly.

*Study the instructions carefully. The items refer to the parts list and service kits section.  
Handle scrap correctly.*

---

### 5.2 Dismantling – single shaft seal

---

#### **Step 1**

Remove nuts (8) and yoke (5).

---

#### **Step 2**

Remove pump casing (7) and O-ring (10) from back plate (9), (use a plastic hammer, if necessary).

---

#### **Step 3**

Turn impeller (6) anticlockwise and remove it from pump shaft (26), (use a plastic hammer, if necessary).

---

#### **Step 4**

1. Remove back plate (9).
  2. The shaft seal is now accessible.
- 

#### **Step 5**

Turn nut (24) clockwise and remove it from stationary seal ring (23).

---

#### **Step 6**

Remove stationary seal ring (23) and seal (25) from back plate (9).

---

#### **Step 7**

1. Remove rotating seal ring (27) and O-ring (29) from pump shaft (26).
  2. Remove spring (22) from the rotating seal ring.
- 

#### **Step 8**

1. Remove screws (2) and washers (3).
  2. Remove adaptor (4).
  3. Remove pin (28) and thrower (21).
  4. Remove pump shaft (26) from the motor shaft.
-

## 5 Maintenance

---

*Study the instructions carefully. The items refer to the parts list and service kits section.  
Handle scrap correctly.*

---

### 5.3 Dismantling – flushed shaft seal

---

#### Step 1

1. Remove nuts (8) and yoke (5).
  2. Remove pump casing (7) and O-ring (10) from back plate (9), (use a plastic hammer, if necessary).
  3. Turn impeller (6) anticlockwise and remove it from pump shaft (42), (use a plastic hammer, if necessary).
- 

#### Step 2

Remove back plate (9) together with the complete shaft seal and intermediate flange (44).

---

#### Step 3

1. Remove flushing tubes (45)
  2. Turn seal housing (35) clockwise and remove it together with fastening ring (43).
  3. Remove O-ring (41) from the fastening ring.
- 

#### Step 4

Remove stationary seal ring (23) and seal (25) from back plate (9).

---

#### Step 5

1. Remove screws (39).
  2. Remove fastening ring (43) and O-ring (40) from seal housing (35).
  3. The shaft seal is now accessible.
- 

#### Step 6

Remove rotating seal rings (36), O-rings (29), washers (30), spring (37) and spacer (31) from seal housing (35).

---

#### Step 7

Remove stationary seal ring (33) and O-ring (32) from seal housing (35).

---

#### Step 8

1. Remove screws (2) and washers (3).
  2. Remove adaptor (4).
  3. Remove pin (34).
  4. Remove pump shaft (42) from the motor shaft.
-

*Study the instructions carefully. The items refer to the parts list and service kits section.  
Lubricate the rubber seals before fitting them.*

---

### 5.4 Assembly – single shaft seal

---

#### Step 1

1. Fit thrower (21) on pump shaft (26).
  2. Fit the pump shaft on the motor shaft and lock it with pin (28).
  3. Fit adaptor (4), washers (3) and screws (2).
  4. Lubricate the external surface of the pump shaft.
- 

#### Step 2

1. Lubricate O-ring (29).
2. Fit the O-ring on pump shaft (26).

#### CAUTION

Ensure that the driver on the drive ring enters the notch in the rotating seal ring.

---

#### Step 3

1. Lubricate the inner surface of rotating seal ring (27).
  2. Fit spring (22) on the rotating seal ring.
  3. Push the rotating seal ring over O-ring (29) as far as possible against the shoulder.
- 

#### Step 4

1. Fit seal ring (25) and stationary seal ring (23) in back plate (9)
  2. Fit nut (24), turn it **anticlockwise** and tighten.
- 

#### Step 5

Fit back plate (9) together with the stationary shaft seal parts on adaptor (4).

---

#### Step 6

1. Fit impeller (6) with the rounded part of the hub outwards and turn it clockwise.
  2. Check the clearance between back plate (9) and the impeller (0.8-1 mm).
- 

#### Step 7

1. Lubricate O-ring (10) and fit it on back plate (9).
  2. Fit pump casing (7).
- 

#### Step 8

Fit yoke (5) and nuts (8).

---

## 5 Maintenance

---

Study the instructions carefully. The items refer to the parts list and service kits section.  
Lubricate the rubber seals before fitting them.

---

### 5.5 Assembly – flushed shaft seal

---

#### Step 1

1. Fit pump shaft (42) on the motor shaft and lock it with pin (34).
  2. Fit adaptor (4), washers (3) and screws (2).
  3. Lubricate the external surface of the pump shaft.
- 

#### Step 2

1. Fit seal (25) and stationary seal ring (23) on back plate (9)
  2. Fit O-ring (41) in fastening ring (43).
  3. Fit the fastening ring to the back plate, turn it **anticlockwise** and tighten.
- 

#### Step 3

1. Push assembly mandrel (46) through the hole in the assembled back plate.
2. Fit rotating seal rings (36), O-rings (29), washers (30), spring (37) and spacer (31).

Assemble the shaft seal in correct order!

**NOTE!** Ensure correct position of the joint if using Teflon O-rings.

---

#### Step 4

1. Fit O-rings (32, 40) and stationary seal ring (33) in seal housing (35).
  2. Tighten the seal housing to fastening ring (43) by means of screws (39).
  3. Fit intermediate flange (44) on back plate (9).
  4. Fit and tighten flushing tubes (45).
- 

#### Step 5

1. Push mandrel (46) together with the shaft seal parts onto pump shaft (42).
  2. Push back plate (9) together with the shaft seal into its correct position.
- 

#### Step 6

1. Fit impeller (6) with the rounded parts of the hub outwards and turn it clockwise.
  2. Check the clearance between back plate (9) and the impeller (0.8-1 mm).
- 

#### Step 7

1. Lubricate O-ring (10) and fit it on back plate (9).
  2. Fit pump casing (7).
- 

#### Step 8

Fit yoke (5) and nuts (8).

---

### 5.6 Assembly – new shaft

---

#### Step 1

1. Fit the pump shaft to the motor shaft.  
(Hit a mark in the motor shaft with a chisel before the pump shaft is mounted.  
This way the shaft can be adjusted with a hammer and not move unintentionally)
  2. Fit the adaptor part, back plate and impeller.
  3. Adjust shaft position so that there is about 1 mm between the impeller and back plate.
  4. Remove impeller, back plate and adapter so only the pump shaft is remaining, in the right position.
  5. Drill a hole ( $\varnothing 4 \pm 0.2$ ) through both motor shaft and pump shaft with the pump shaft in the right position.
  6. The hole must NOT be drilled in the keyway of the motor.
  7. Mount  $\varnothing 4 \times 30$  pin using a small hammer.
-

*It is important to observe the technical data during installation, operation and maintenance.  
Inform personnel about the technical data.*

## 6.1 Technical data

Centrifugal pump FM-OS is designed for use in food, pharmaceutical, chemical and other industries where acid-resistant steel is resistant to the products to be pumped. This instruction manual is part of the delivery. Study the instructions carefully. The standard delivery does not include the test certificate. This can be supplied on request.

Data	
Max. inlet pressure	400 kPa (4 bar) (58 psi)
Temperature range	-10°C to +140°C (EPDM) (14 to 284°F)
Impeller diameter, FM-OS/95	95 mm
Impeller diameter, FM-OS/115	115 mm
Max. speed:	4000 rpm
Materials	
Product wetted steel parts	AISI 316L
Other steel parts	Stainless steel
Product wetted seals	Nitrile (NBR), (standard)
Finish	Semi-bright
Alternative seals	EPDM, Viton (FPM) and Teflon (PTFE)
Shaft seal	
Seal types	Mechanical single or flushed seal
Max. water pressure (flushed seal)	Normally atmospheric (max. 1 bar) (max. 14.5 psi)
Water consumption (flushed seal)	0.25 - 0.5 l/min. (0.07-0.13 gal)
Material, stationary seal ring	AISI 329 with sealing surface of silicon carbide
Material, rotating seal ring	Carbon (standard) or silicon carbide
Material, O-rings	Nitrile (NBR), (standard)
Alternative material, O-rings	EPDM, Viton (FPM) and Teflon (PTFE)
Motor	
Standard foot-flanged motor according to IEC metric standard	
2 pol = 3000/3600 rpm. at 50/60 Hz	
IP55 (with drain holes sealed with labyrinth plug), insulation class F	
Motor sizes (kW), 50 Hz	1.1 kW
Motor sizes (kW), 60 Hz	1.3 kW

For further information - see PD sheet.

### Transportation of the pump or the pump unit:

- Never lift or elevate the pump in any way other than as described in this manual
- Always drain the pump head and accessories of any liquid
- Always ensure that no leakage of lubricants can occur
- Always transport the pump in its upright position
- Always ensure that the unit is securely fixed during transportation
- Always use original packaging or similar during transportation

## 6 Technical data

---

*It is important to observe the technical data during installation, operation and maintenance.  
Inform personnel about the technical data.*

---

### 6.2 Torque specifications

---

The table below specifies the tightening torques for the screws, bolts and nuts in this pump.

Always use the following torques if no other values are stated. This can be a matter of personal safety.

Size	Tightening torque	
	Nm	lbf-ft
M8	20	14.8
M10	40	29.5
M12	67	49.0
M14	110	81.0

---

### 6.3 Weight (kg)

---

Pump Type: FM-OS

Size	Motor 80 1,1kW
FM-OS	34

Weight can vary depending of configuration. Weight is only to be seen as a reference value during handling, transporting and packaging.

---



*It is important to observe the technical data during installation, operation and maintenance.  
Inform personnel about the technical data.*

## 6.4 Noise emission

Pump Type	Sound pressure level (dBA)
LKH-5	60
LKH-10	69
LKH-15	72
LKH-20	70
LKH-25	74
LKH-35	71
LKH-40	75
LKH-45	70
LKH-50	75
LKH-60	77
LKH-70	88
LKH-75	79
LKH-85	86
LKH-90	75
LKH-112	70
LKH-113	69
LKH-114	68
LKH-122	75
LKH-123	77
LKH-124	80
SolidC-1	68
SolidC-2	72
SolidC-3	73
SolidC-4	72
MR-166	76
MR-185	82
MR-200	81
MR-300	82
GM	54
FM-OS	61

The above LKH noise levels are the same for LKHDPF, LKHI, LKH UltraPure, LKH Evap, LKHex.  
The above SolidC noise levels are the same for SolidC UltraPure.

The noise measurements have been carried out using the original motor and shroud at the approximate Best Efficiency Point (BEP) with water at ambient temperature and at 50 Hz.

Very often the noise level generated by the flow through the process system (e.g. valves, pipes, tanks etc.) is much higher than that generated by the pump itself. Therefore, it is important to consider the noise level from the total system and take the necessary precautions with regard to personal safety if required.



The drawing shows FM-OS. The items refer to the parts list on the part on the page.

7.1 Drawings

FM-OS, Single shaft seal

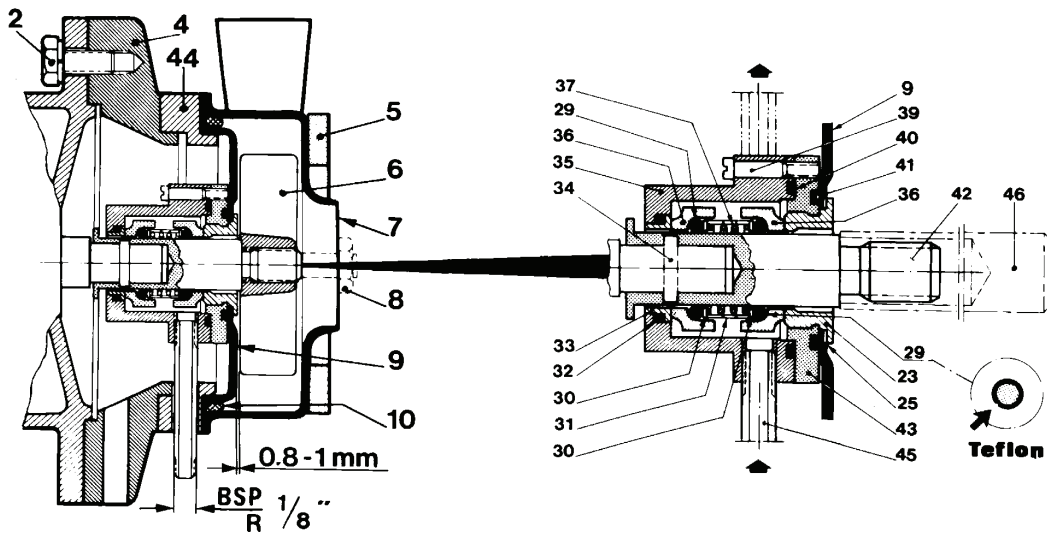
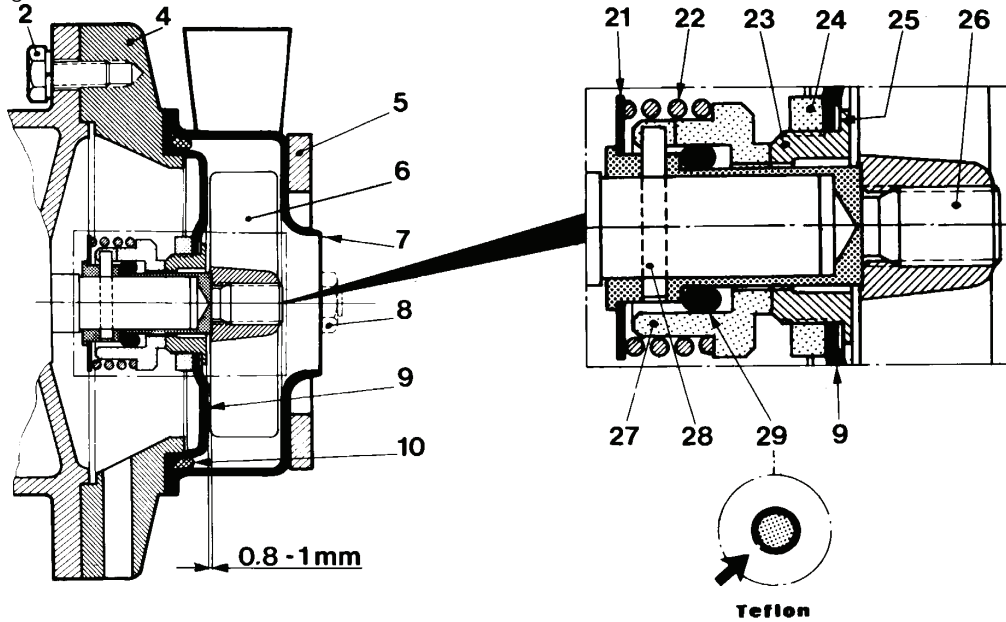

FM-OS, Flushed shaft seal



## 7 Parts list and service kits

The drawing includes all items of the pump.

### Parts list

Pos.	Qty	Denomination
1	1	Motor IEC80
2	4	Screw
3	4	Spring washer
4	1	Adaptor
5	1	Yoke
6	1	Impeller
7a	1	Pump casing with sanitary fittings 51 mm inlet and outlet
	1	ISO male
	1	SMS
	1	DIN
	1	ISO clamp
	1	BS
7b	1	Pump casing flanges DN 50 inlet and DN 40 outlet
	1	Pump casing with flanges DN 50 inlet/DN 50 outlet
8	2	Nut
9	1	Back plate
10	1	O-ring
11	2	Stud bolt
21	1	Thrower
22	1	Spring
23	1	Stationary seal ring, SiC
24	1	Nut
25	1	Seal
26	1	Pump shaft
27	1	Rotating seal ring, carbon
	1	Rotating seal ring, SiC
28	1	Tubular spring pin
29	1	O-ring
47	1	Shroud complete
48	1	Support bar, left
49	1	Support bar, right
50	4	Nut
51	4	Washer
52	4	Leg
53	4	Screw
54	4	Washer
55	4	Washer
56	4	Nut
57	4	Screw

### Service kits

Denomination	FM-0S/95	FM-0S/115
<b>Service kit</b>		
Service kit, NBR .....	9611921050	
Service kit, EPDM .....	9611921051	
Service kit, FPM .....	9611921052	
Service kit, PTFE .....	9611921053	

## 7 Parts list and service kits

The drawing includes all items of the pump.

### 7.3 FM-OS Centrifugal pump, flushed shaft seal

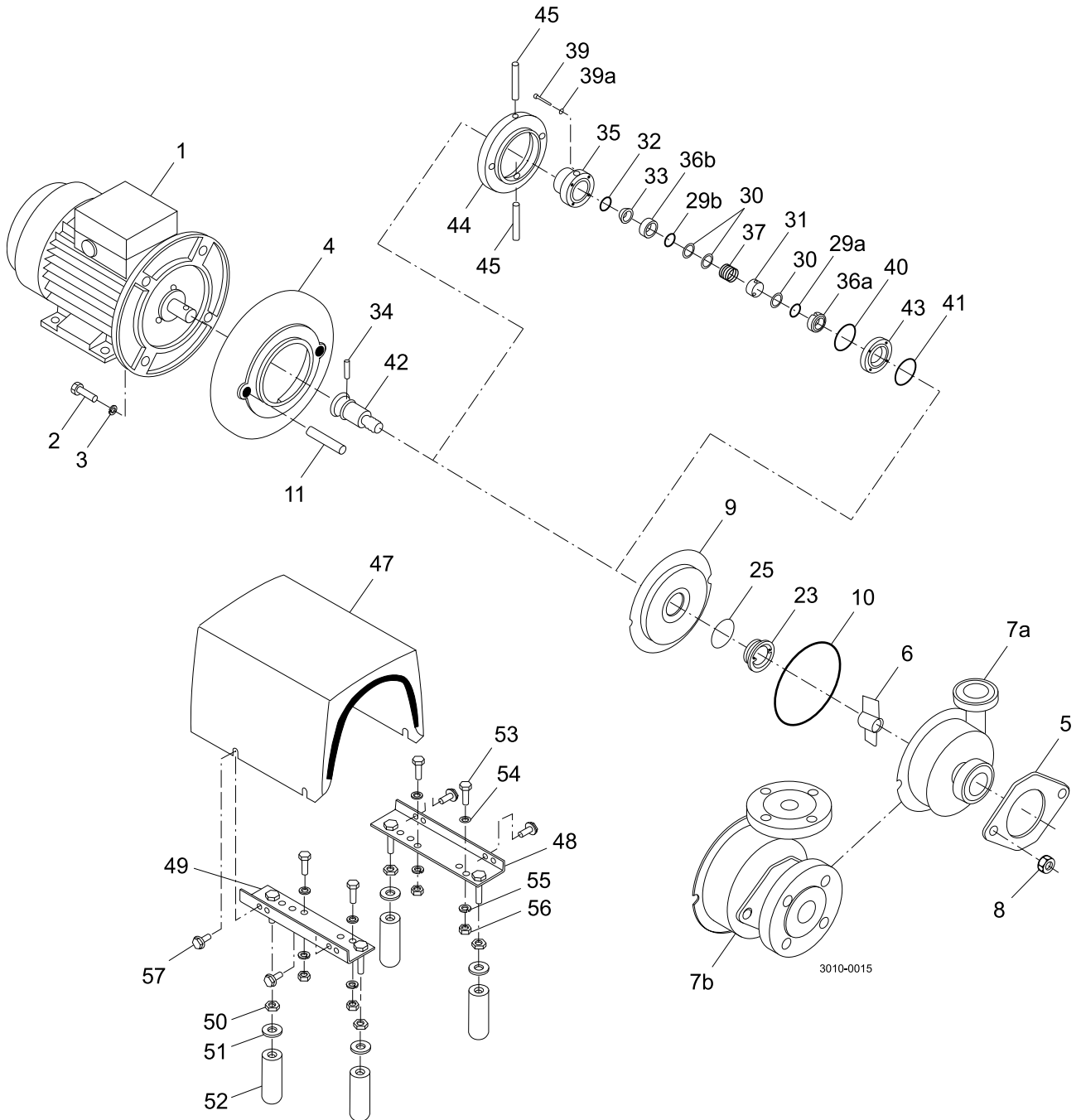

## 7 Parts list and service kits

The drawing includes all items of the pump.

### Parts list

Pos.	Qty	Denomination
1	1	Motor IEC
2	4	Screw
3	4	Spring washer
4	1	Adaptor
5	1	Yoke
6	1	Impeller
7a	1	Pump casing with sanitary fittings
	1	ISO male
	1	SMS
	1	DIN
	1	ISO clamp
	1	BS
	1	Pump casing flanges DN 50
7b	1	Pump casing flanges
	1	Pump casing
8	2	Nut
9	1	Back plate
10	1	O-ring
11	2	Stud bolt
23	1	Stationary seal ring, SiC
25	1	Seal
29a	1	O-ring, front
29b	1	O-ring, back
30	3	Washer
31	1	Spacer
32	1	O-ring
33	1	Stationary seal ring
34	1	Tubular spring pin
35	1	Seal housing
36a+b	2	Rotating seal ring, carbon
37	1	Spring
39	4	Screw
39a	4	Washer
40	1	O-ring
41	1	O-ring
42	1	Pump shaft
43	1	Fastening ring
44	1	Intermediate flange
45	2	Flushing tube
46	1	Assembly mandrel (not shown)
47	1	Shroud complete
48	1	Support bar, left
49	1	Support bar, right
50	4	Nut
51	4	Washer
52	4	Leg
53	4	Screw
54	4	Washer
55	4	Washer
56	4	Nut
57	4	Screw

### Service kits

Denomination	FM-0S/95	FM-0S/115
Service kit		
Service kit, NBR .....	9611921054	
Service kit, EPDM .....	9611921055	
Service kit, FPM .....	9611921056	
Service kit, PTFE .....	9611921057	







**How to contact Alfa Laval**

Contact details for all countries are continually updated on our website.

Please visit [www.alfalaval.com](http://www.alfalaval.com) to access the information directly.

© Alfa Laval Corporate AB

This document and its contents is owned by Alfa Laval Corporate AB and protected by laws governing intellectual property and thereto related rights. It is the responsibility of the user of this document to comply with all applicable intellectual property laws. Without limiting any rights related to this document, no part of this document may be copied, reproduced or transmitted in any form or by any means (electronic, mechanical, photocopying, recording, or otherwise), or for any purpose, without the expressed permission of Alfa Laval Corporate AB. Alfa Laval Corporate AB will enforce its rights related to this document to the fullest extent of the law, including the seeking of criminal prosecution.